

## Machine design without the overhead

Making automated designs in 3D CAD doesn't have to be complicated if you choose the right technology

[www.siemens.com/solidedge](http://www.siemens.com/solidedge)

white paper

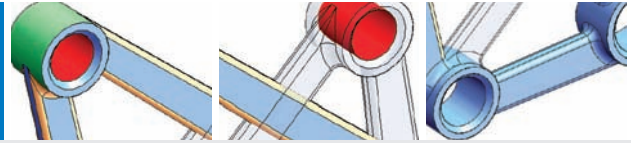

- ▶ Component re-use tends to be high in machine design. As a result, implementing the right technology can greatly simplify the modeling process. Solid Edge® with synchronous technology software provides improved modeling methods that speed both 3D adoption and the overall modeling process. This white paper explains how machine designers who strive for higher product quality, fewer prototypes, and reduced design times can adopt a better 3D technology that is especially suited for their needs.

# PLM Software

Answers for industry.

**SIEMENS**

## Table of contents

Executive summary	1
Why machine designers struggle	1
Faster adoption	3
Leveraging 2D into 3D design	5
Flexible change using parametrics on demand	6
Additional synchronous technology advantages	9
Conclusion	11

## ▶ Executive summary

Most machine designers are aware of that 3D modeling enables them to deliver higher product quality with fewer prototypes to reduce design times. While different machines often produce very different products, many of the process steps used in designing today's machines can be similar. Operations such as transfer, positioning, stamping and folding are quite common regardless of the end product or design process. As a result, component re-use tends to be high in machine design.

A technology that facilitates automated re-use for both in-house and imported models is an important aspect to consider when choosing the right design tool. There are other important factors, however, such as initial system adoption, model creation, 2D integration into assembly design, drawing development, change management, and ECO execution. Solid Edge with synchronous technology software leverages many new and innovative concepts that improve modeling methods, speeding both the overall 3D modeling process.

## ▶ Why machine designers struggle

Engineers know what they need to do; today's challenge is how to do it efficiently. For the most part, 3D design software has not evolved much from the architecture that was introduced in the mid-80s. Despite numerous advancements, their proprietary design and model intelligence doesn't translate between different systems. A recent independent study conducted by the Aberdeen Group indicates that both new and experienced 3D users struggle with managing model design. It also reports that users are challenged with model creation, even though this facet in the design process has improved over time (see figure 1). As a result, designers find it difficult to implement and use 3D CAD.

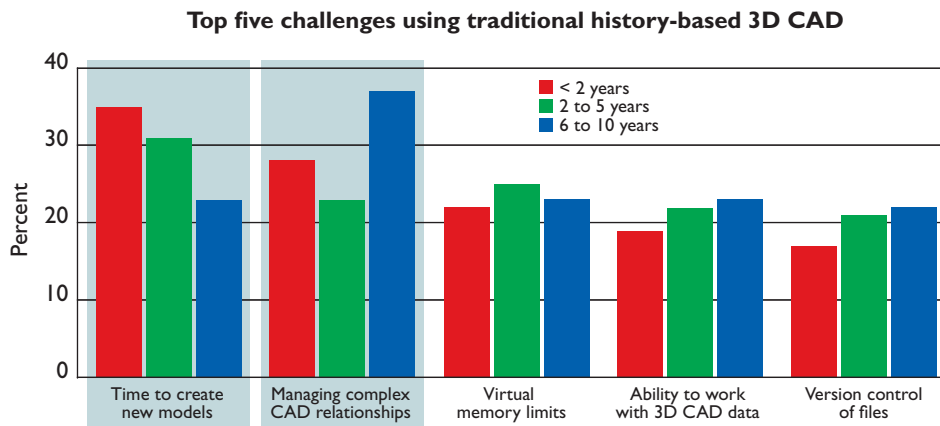

Figure 1: Aberdeen Group survey indicates the top 5 challenges faced by designers using traditional 3D CAD software. The amount of time required to create new models and managing complex CAD relationships are the top challenges for companies using 3D, regardless of when they adopted 3D. Source: Aberdeen Group May 2008.

With this in mind, let's take a look at what design tools are now available and how these improved technologies are eliminating the challenges traditionally faced by machine designers.

### Traditional 3D modeling tools

Most mainstream 3D CAD systems record modeling operations in a feature tree. These parametric or history-based systems use dimensions and features for precise creation and editing. When these dimensions and features are packaged together, they provide a highly automated design system. The downside is history. Getting reliable updates requires a tremendous amount of pre-planning and completed models are inflexible and difficult to change. Editing performance suffers because unrelated features must regenerate during edits. In addition, since individual CAD vendors have their own way of tracking and managing features, models cannot be transferred between systems.

### An explicit modeling approach

Explicit modeling systems provide another technology; they excel at delivering fast performance. However, these systems do not leverage the feature concept, nor do they track the history of operations. As a result, their geometry isn't inter-related. These systems provide fast performance, but they are not able to build intelligent models (which mean users cannot express themselves by saying "this hole can drive that face"). Because of the lack of design automation, few companies use explicit modeling for machine design.

### The best of both worlds

To address capabilities missing in these technologies, Solid Edge with synchronous technology incorporates the best of both worlds. This unique technology combines the speed and flexibility of explicit modeling with precise control of parametric design.

Figure 2 shows how these technologies are combined into a single system. The results to the machine designer is a 3D design tool that's easier to learn, more flexible for implementing design changes and able to handle imported data better. Just as importantly, all of these capabilities can be provided with nearly instant performance.

#### Use case

A-I Engineering is a leader in its sector, producing high tech, high quality molds. In business since 1971, the company has established a reputation for innovative design by engineering complex molds for the aerospace, industrial, medical, power generation, food processing and optical industries.

A-I Engineering needed to reduce its CAD maintenance costs, simplify and accelerate its order-to-delivery process and increase its business opportunities. A-I Engineering implemented Solid Edge with synchronous technology and now delivers parts in a 1/3 of the time, resulting in more business.

"Solid Edge is twice as easy to learn as a traditional CAD system...the user interface and approach are quite intuitive."

*Jim Saugesta, Company Engineer, A-I Engineering*

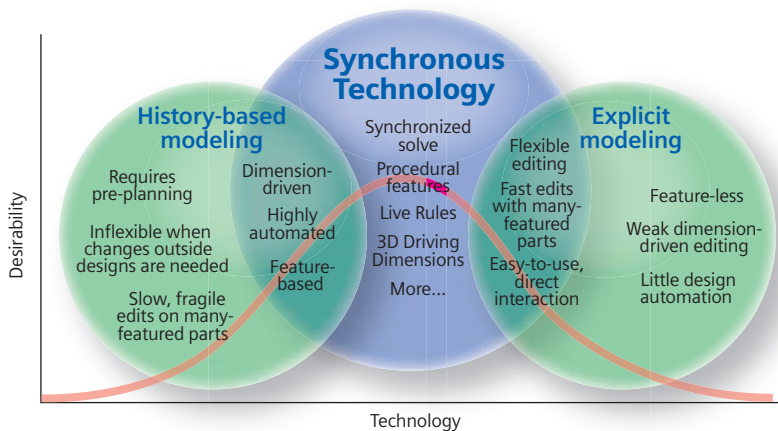

Figure 2: Synchronous technology combines the best capabilities of both explicit and history-based systems, helping users adopt 3D modeling more easily while delivering faster performance.

## ► Faster adoption

Re-use within machine parts tends to be high and designing parts for unknown future demands is challenging. Designs need to be constructed so that key parameters, such as shaft locations, mounting holes or linkage lengths, can be maintained. History-based CAD systems let users build models to meet future needs, but require careful design pre-planning. The following discussion illustrates how Solid Edge with synchronous technology simplifies matters.

### Modeling without order

A breakthrough in design enables users who employ Solid Edge with synchronous technology to create designs without regard for feature order. Users are able to capture ideas fast initially and flexibly deal with change later. For example, figure 3 shows a pillow block where the intent is to maintain the distance from the base to the bearing center (shown in A). The user then adds mounting feet (image B), breaking that intent. Designers using a history-based CAD system can't simply change the initial dimension scheme to include the foot since it doesn't exist during the first step. Manual calculations subtracting the foot thickness are necessary for the fix.

Solid Edge with synchronous technology lets users add both geometry and dimensions regardless of order so there are no parent/child rules to follow. In this example, restoring intent is done by redefining the height dimension to include the base shown in image C. This capability virtually eliminates pre-planning since these 3D driving dimensions can be placed anywhere at any time.

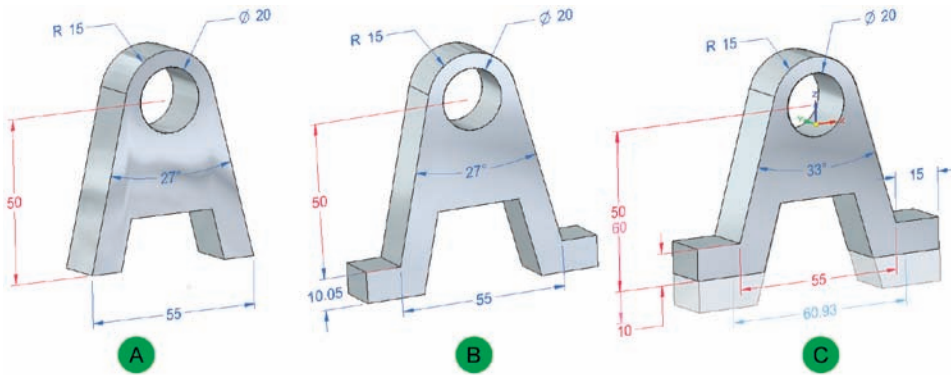

Figure 3: Traditional history-based systems require pre-planning to establish intent. The initial design (image A) is negated with the addition of mounting feet in image B. With synchronous technology, design intent can be established in image C as 3D driving dimensions redefined on the completed model.

## Parametric features

CAD features tend to mimic design operations (such as holes, chamfers and fillets) so that they can be easily understood by machine designers. Added features can be edited by adjusting their parameters, but since features are dependent in history-based systems, they can change unexpectedly from edits to other features. This is a well known issue.

Solid Edge with synchronous technology is feature-based. This enables designers to create models with common manufacturing-like operations. Unlike other systems, Solid Edge features are independent of each other and are less prone to fail during the change process. Traditional CAD systems must regenerate features after upstream changes because of this dependency. For example, notice how the model in figure 4 shows the current operation during an edit. After the change, the missing features attempt to regenerate. In contrast, Solid Edge features are independent (inset) edits that are made to the completed model. As a result, edits don't inadvertently break the intent of other features and you see results in real time.

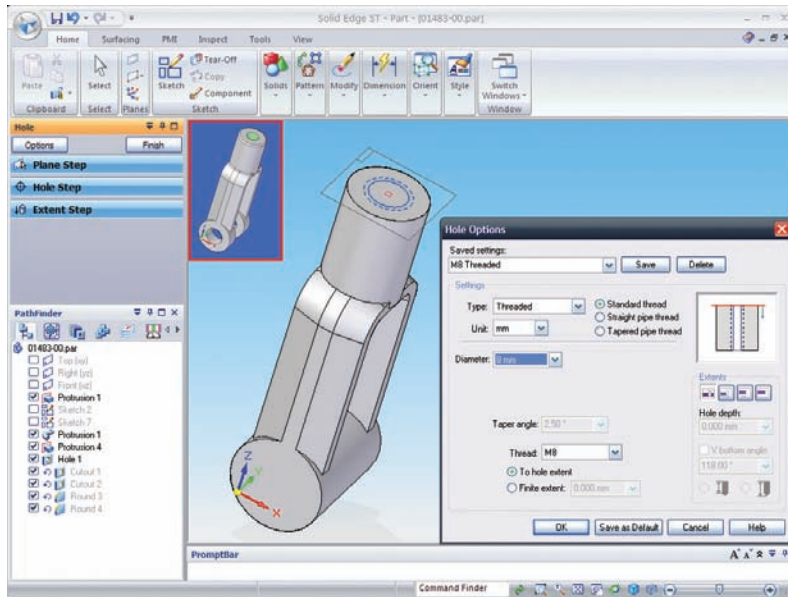

Figure 4: Features in history-based systems are dependent. As a result, models “roll back” to how they looked when the feature was originally created. Subsequent features must regenerate after the edits, risking failures. Solid Edge with synchronous technology uses a different scheme (inset) so that real-time edits are made to the model in its final state.

## ► Leveraging 2D into 3D design

Because of the nature of machine design, many design problems can be solved with 2D. The challenge is how to leverage 2D solutions in 3D. Moving part drawings into 3D can be straightforward; however, assembly layouts tend to be more complicated because they can contain envelopes, parts lists and component details. The following subsections explain how Solid Edge with synchronous technology can be leveraged to bring 2D drawings into assembly design.

### Define the parts list before 3D

Defining the parts list of a new product early in the process helps designers prepare cost estimates before expensive design time is spent. Outlining key components in 2D is a common practice, but doing the same in traditional 3D generally requires physical parts. A unique Solid Edge approach allows designers to define a complete assembly structure with “virtual components.” Figure 5 shows how an assembly structure can use these components. Manufacturing, purchasing and management teams can quickly size up the scope of a new product. Imported drawings can be linked to each virtual component to later assist the 3D part – and 3D parts can be re-used if they already exist.

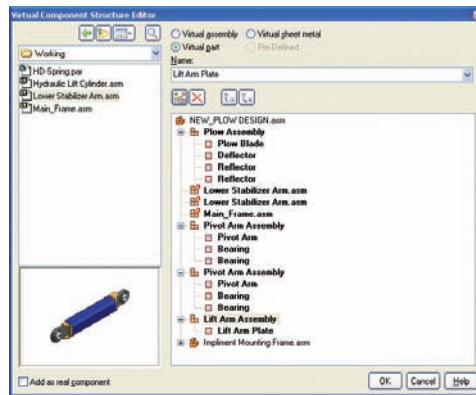

Figure 5: A complete assembly can be created without physical components. Defining the assembly structure with virtual components lets designers make changes faster during the conceptual development stage.

### Using 2D layouts to drive 3D assemblies

Designers understand the important role that layouts play in machine design. Regardless of industry, it's common practice to initially define the fit and position of parts or complete machines in 2D. A hybrid Solid Edge approach lets users mix and match 2D layouts with 3D components. Layouts can be created or imported from other systems, optimized with Goal Seek, then used to construct 3D components. Figure 6 shows an assembly layout that defines the locations of the machine components. If the location of a machine needs to be moved, the 2D sketch is simply edited.

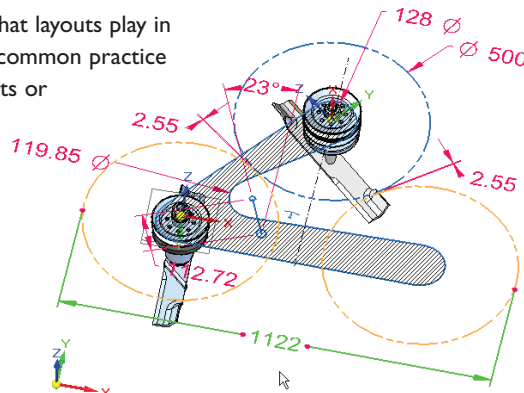

Figure 6: 2D drawings can be part of the 3D design process. Native or imported drawings are used to lay out components and then are optimized with Goal Seek.

## ► Flexible change using parametrics on demand

When it comes to parts or assemblies, there are usually a few parameters, such as shaft locations, mounting hole patterns or linkage length, that must be maintained. When making automated design changes where a single modification affects one or more parts of a model, preserving design parameters is the challenge. While history-based systems can facilitate this capability, they usually require a carefully built constraint system.

### Built-in design intent

A unique concept in synchronous technology called Live Rules simplifies automated change. Live Rules finds and maintains geometric conditions, such as concentric, tangent, symmetric, horizontal or vertical conditions, during an edit – even if their rules aren't established. Options are available to override these conditions or find and preserve other geometric conditions. Because features are history-free, edits can affect previously created operations. For example, as the user drags the green face in figure 7, geometric conditions such as tangent blends (yellow faces), concentric mounting holes (red faces) and tangent connecting arms (blue face) are automatically retained. In this example, Live Rules eliminated the need to plan the modeling process in order to get the right results.

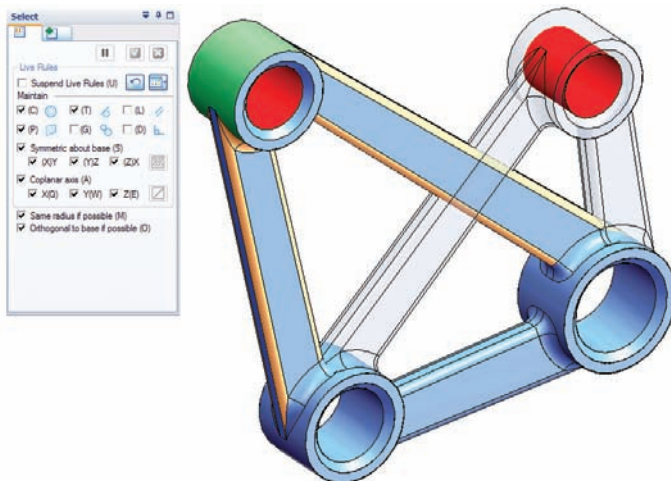

Figure 7: Live Rules automatically recognizes geometric conditions, such as coplanar, tangency and concentricity conditions. Model edits are as easy as dragging a single face in Solid Edge with synchronous technology.

## Dimension-driven design

All designs require precise change control; this is done with dimensions in most systems. Solid Edge with synchronous technology offers dimensional control but works much differently than history-based CAD systems. With Solid Edge, users can place “3D driving dimensions” to geometric elements during feature creation or to a completed model. Dimensions also can be linked together with formulas so that a single change can control multiple areas. The dimensioning scheme in history-based system is done at feature creation time and only to underlying 2D geometry that exists at that point in time. Synchronous technology’s flexibility is shown in figures 8 to 10, where the design intent of a pillow block will be reconfigured on the fly.

Figure 8 illustrates a change to the overall height by modifying a 3D driving dimension. This dimension was added to the completed design and is independent from any of the modeling steps. As the height changes, the tapered sides vary to keep the base size fixed. Making the same edit in a history-based design requires users to carefully build the base 2D to include both the support and mounting feet.

Now, suppose the angle between the tapered sides must remain fixed. Reconfiguring the initial intent is done by adding a locked 3D driving dimension between those faces and floating the height dimension (see figure 9). As the height is changed, the taper is fixed and the base gets wider to allow the edit. Making these same edits in a history-based design requires users to re-constrain the base 2D sketch – assuming it includes all feature definitions.

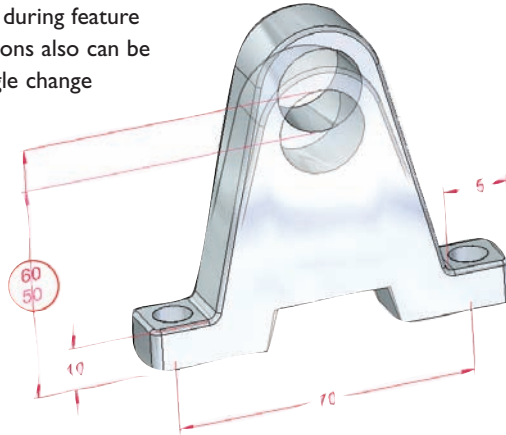

Figure 8: In synchronous technology, 3D driving dimensions are used to control size and position of the 3D geometry. In this example, a 3D driving dimension is changed to drive the distance from the base of the pillow block to the center of the bearing journal.

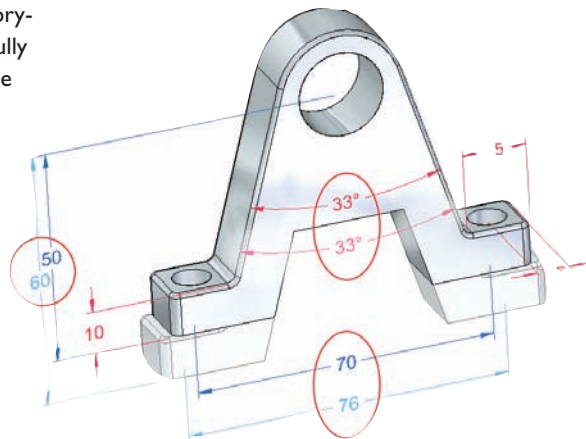

Figure 9: 3D driving dimensions can be locked or unlocked to add design intent. In this example, the angle of the sides is preserved while the mounting hole centers become larger as the overall height is increased.

Finally, let's increase the distance between the mounting holes but fix the height. To achieve this new intent, the height will be locked and both the base and taper will be allowed to float. As the mounting hole distance is increased, the taper changes as shown in figure 10. Other dimensions can be added and locked or floated depending on the desired results; but more importantly, notice how easy it is to change a design to accommodate future requirements. Synchronous technology greatly simplifies the construction and configuration of automated 3D designs.

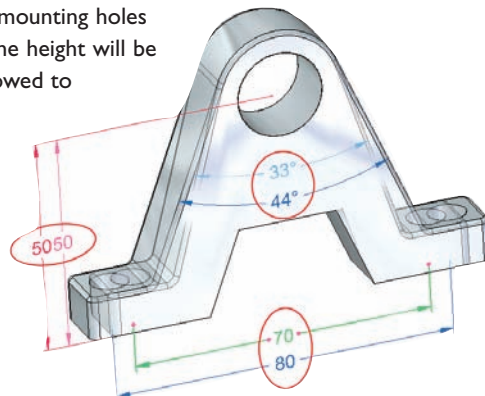

Figure 10: Design intent is changed by locking or unlocking 3D driving dimensions. Unlocking the angle of the sides and locking the overall height allows the main body angle to adjust while the mounting hole centers are changed.

### Geometric conditions made easy

Automated designs can also be established with geometric relationships, including concentric, tangent and horizontal/vertical relationships. As shown, Live Rules manages these conditions during edits, but less obvious conditions, such as parallel and perpendicular conditions, may need to be stored for permanent use. Solid Edge is unique because it enables users to apply these conditions to a completed 3D model regardless of order. History-based systems manage geometric intent through constraints applied to 2D sketches during feature creation. This forces careful feature construction in the right order.

Figure 11 shows a model where several faces (in green) must be kept parallel to a face being rotated (purple). Live Rules finds the obvious ones, but the goal is to establish these less common relationships for future edits. Solid Edge's Relate feature lets designers set these conditions directly to the 3D. It's important to note that each face in this example was created in a different operation. But since features are independent, the last face can drive the first face. Edits in a history-based CAD system must be driven from the parent feature. This forces users to study feature trees to understand where that parent is.

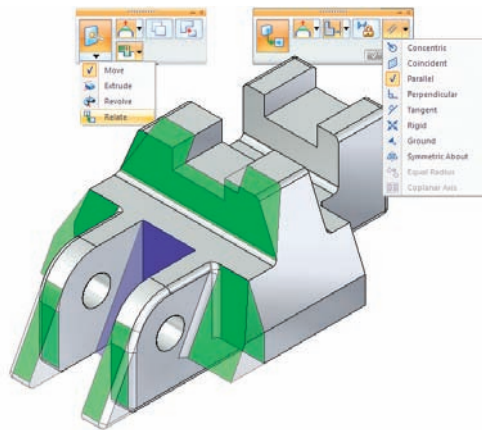

Figure 11: Users can employ Solid Edge's Relate command to add and maintain additional design intent regardless of feature order, even when the intent was not originally planned.

Leveraging an easy-to-use automated model enables companies to facilitate machine design re-use and thereby speed overall development. History-based systems support this capability; but building parametric models in synchronous technology is a much simpler process. Intent can be found and maintained without having to add formal constraints. Also, dimensions and geometric relationships can be added directly to a completed model to preserve intent for future edits.

## ► Additional synchronous technology advantages

### Significant performance gains

One common aspect found in many machines is a high parts count. It's common to find machines with thousands of parts. As a result, even simple changes often affect multiple parts. Synchronous technology eliminates feature history, which enables designers to minimize update times. Edits to parts happen almost instantly and since there is less chance for feature failures, designers spend less time inspecting and fixing the results. Figure 12 shows a performance comparison between traditional (history-based) methods and synchronous technology. Notice how edit times for traditional 3D increase with model size, while synchronous technology edit times are just a few seconds regardless of model complexity. In addition, since synchronous-based models doesn't store complex history trees, smaller file sizes speed open and save times.

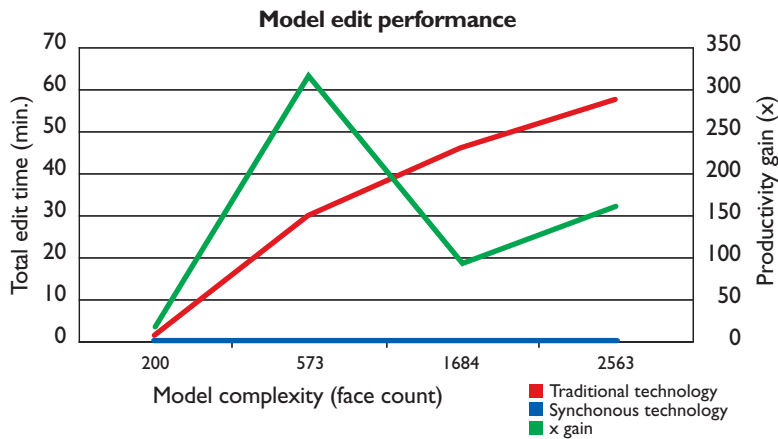

Figure 12: Edit performance comparison between traditional (history-based) and synchronous technology. As expected, history scales with size; however, change speed using synchronous technology is flat.

### Re-using imported models

Because of commonalities between different machines, re-use is a key contributor to machine design productivity. During design, some parts can be re-used with no change; others require modification. Leveraging supplier components is a common practice, but unless the same CAD tool is used, edits in traditional 3D are done with a “hack and whack” strategy. While direct editing tools are available for these traditional systems, only simple changes can be made since changes only happen to the selected face. In contrast, let's see how Solid Edge with synchronous technology addresses edits to imported models.

Figure 13 shows a complex imported part that needs the long interior rib to be moved. Most designers consider imported parts to be a “dumb solid” even though they contain valuable information. You can infer from the model that the concentric faces for the bearing journal and a plethora of co-planar faces should probably stay as is. Physical relationships shouldn't be

needed for such obvious conditions. These relationships are preserved automatically; adding a 3D driving dimension to the rib and a locked dimension to preserve the rib thickness facilitates a precise edit. As the rib is moved, Live Rules finds other coincident ribs and updates them as well. Because Solid Edge with synchronous technology can edit imported data in the same manner as native models, designers have total control over data re-use.

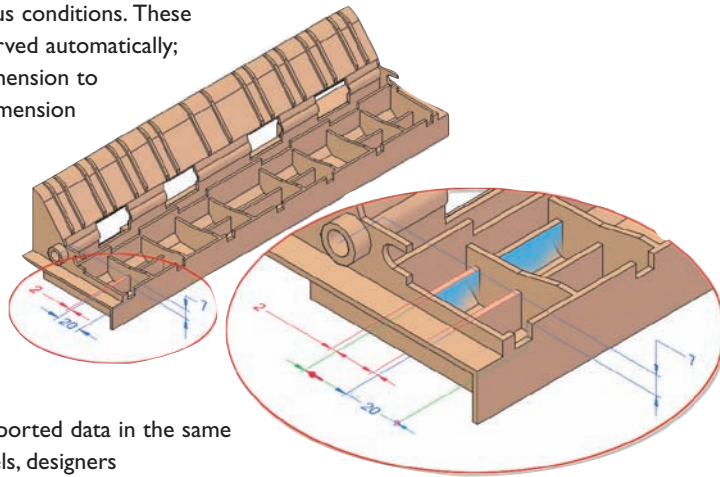

Figure 13: You can edit imported data as though it were your own in Solid Edge with synchronous technology. Parametric control works just as well with imported data as for native Solid Edge files.

## Managing it all

Managing parts data is extremely important since many machines contain higher parts counts. Regardless of the complexity of the machine, data management requirements can range from basic searching and vaulting to process management. The product data management (PDM) capabilities offered by Solid Edge provide the scalability that companies need to meet their future requirements while being totally transparent to their end user communities.

Solid Edge provides a scalable solution that meet the needs a single design department or it can be expanded to satisfy the requirements of thousands designers spread across a global operation. Starting with Solid Edge Insight, single site design data management can be implemented with the lowest total cost of ownership. As data management needs grow, Teamcenter® Express software can be deployed as a preconfigured collaboration solution for multi-CAD installations that manage tasks and processes across multiple departments. Finally, a full Teamcenter software platform implementation can provide a fully configurable engineering process and knowledge solution for a global enterprise. Figure 14 shows how each of these solutions fits together.

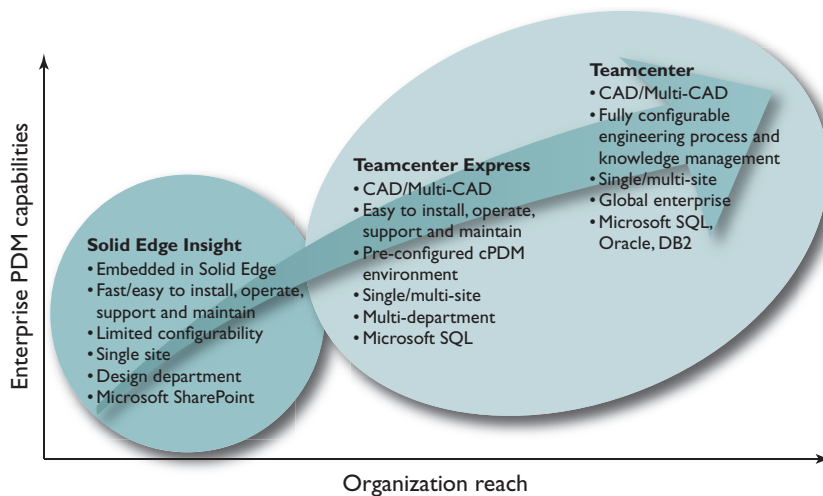

Figure 14: Regardless of organizational size, your data management needs can easily scaled and accommodated.

## Use case

Industrial Control Associates, Inc. (ICA) provides custom machinery, complete installation, turn-key integration and custom robotics for non-destructive testing systems across a wide range of industries.

Faced with competition from larger companies and a challenging economic climate, ICA turned to Solid Edge with synchronous technology. Faster design and the ability to use customer CAD data regardless of format enabled ICA to experience a 30 percent reduction in its design phase, ultimately helping to win new business.

“When we design testing machinery, we need to use the customer’s assembly data no matter what system it was designed in.”

Brian Hare, CEO, Industrial Control Associates

## ▶ Conclusion

Getting the promise of a 3D design solution can be done using Solid Edge with synchronous technology. Machine designers who strive for higher product quality, fewer prototypes and reduced design times can adopt this technology today. The unique approach of Solid Edge with synchronous technology combines the speed and flexibility of explicit modeling with the precise control of parametric design. Solid Edge simplifies adoption, integrates 2D into 3D, provides more flexible edits and leverages supplier data. When coupled with an integrated data management system, designers have the ultimate 3D design solution.

## About Siemens PLM Software

Siemens PLM Software, a business unit of the Siemens Industry Automation Division, is a leading global provider of product lifecycle management (PLM) software and services with 6.7 million licensed seats and more than 63,000 customers worldwide. Headquartered in Plano, Texas, Siemens PLM Software works collaboratively with companies to deliver open solutions that help them turn more ideas into successful products. For more information on Siemens PLM Software products and services, visit [www.siemens.com/plm](http://www.siemens.com/plm).

### Siemens PLM Software

#### Americas

800 807 2200  
Fax 314 264 8922

[www.siemens.com/plm](http://www.siemens.com/plm)



edge

»» EDGE plm software Pty Ltd

Unit 16 / 94-102 keys road  
moorabbin victoria 3189

**1300 883 653**  
[www.edgeplm.com.au](http://www.edgeplm.com.au)

© 2010 Siemens Product Lifecycle Management Software Inc. All rights reserved. Siemens and the Siemens logo are registered trademarks of Siemens AG. D-Cubed, Femap, Geolus, GO PLM, I-deas, Insight, Jack, JT, NX, Parasolid, Solid Edge, Teamcenter, Tecnomatix and Velocity Series are trademarks or registered trademarks of Siemens Product Lifecycle Management Software Inc. or its subsidiaries in the United States and in other countries. All other logos, trademarks, registered trademarks or service marks used herein are the property of their respective holders.

W14 20179 3/10 B